

# MÉCANISME ÉLECTRIQUE POUR PLAN DE TRAVAIL EN ANGLE

ITAR

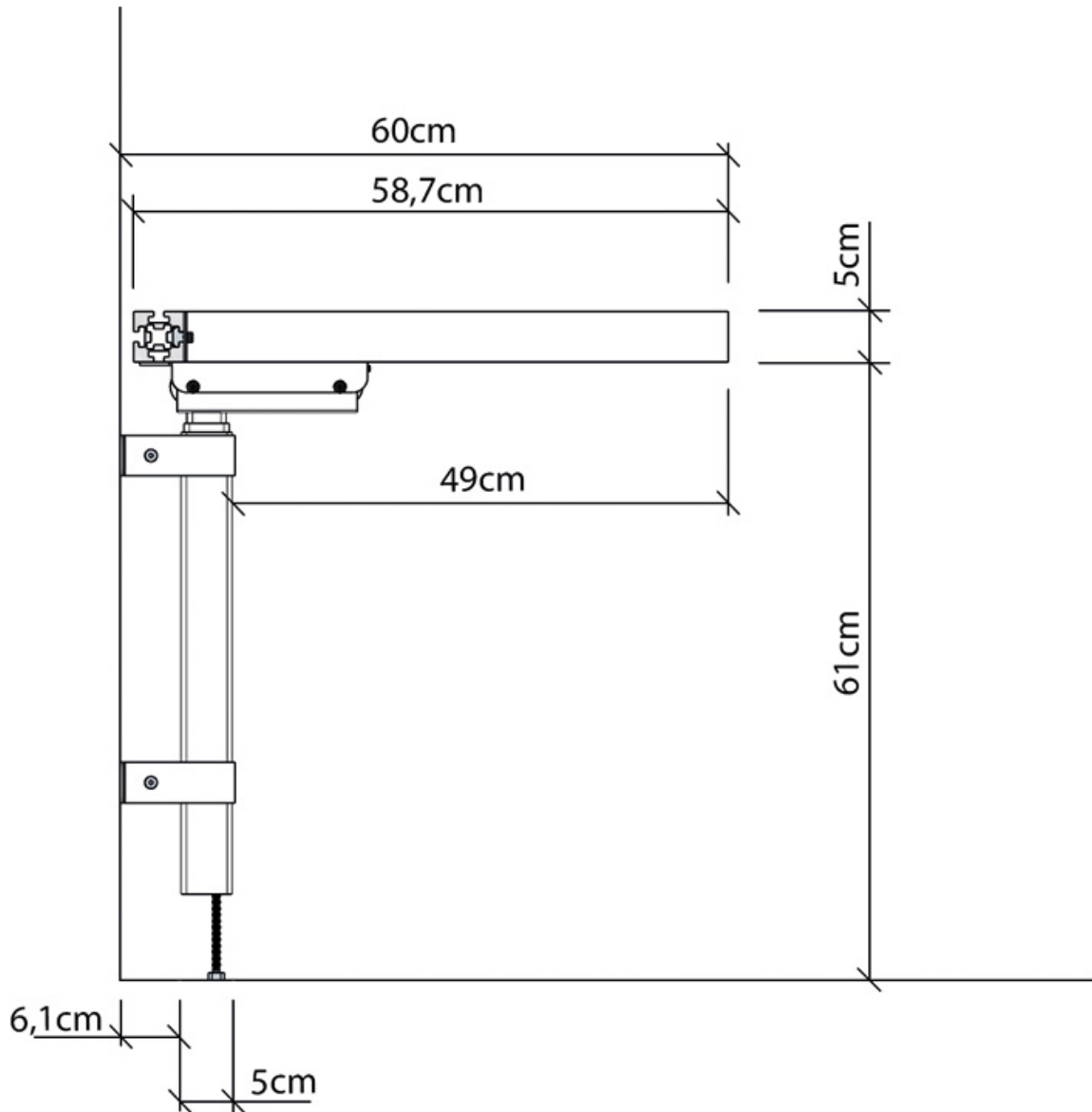

<https://www.quincabox.fr/mecanisme-electrique-pour-plan-de-travail-en-angle-p59949>



Tel : 02 43 30 41 38

Fax : 02 43 30 26 16

[www.quincabox.fr](http://www.quincabox.fr)

# MÉCANISME ÉLECTRIQUE POUR PLAN DE TRAVAIL EN ANGLE

ITAR

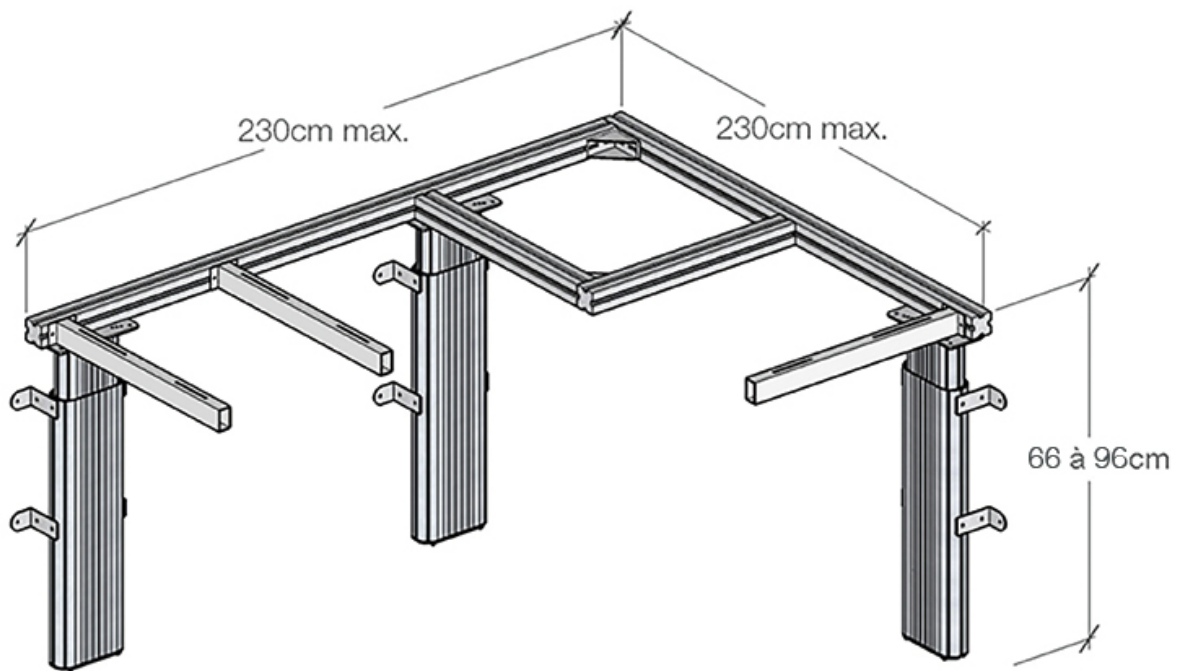

<https://www.quincabox.fr/mecanisme-electrique-pour-plan-de-travail-en-angle-p59949>



Tel : 02 43 30 41 38

Fax : 02 43 30 26 16

[www.quincabox.fr](http://www.quincabox.fr)